



Cambridge International Examinations
Cambridge International General Certificate of Secondary Education

CO-ORDINATED SCIENCES

0654/13

Paper 1 Multiple Choice (Core)

May/June 2017

45 minutes

Additional Materials: Multiple Choice Answer Sheet
Soft clean eraser
Soft pencil (type B or HB is recommended)

* 1 0 5 8 5 2 1 2 4 4 *

READ THESE INSTRUCTIONS FIRST

Write in soft pencil.

Do not use staples, paper clips, glue or correction fluid.

Write your name, Centre number and candidate number on the Answer Sheet in the spaces provided unless this has been done for you.

DO NOT WRITE IN ANY BARCODES.

There are **forty** questions on this paper. Answer **all** questions. For each question there are four possible answers **A, B, C** and **D**.

Choose the **one** you consider correct and record your choice in **soft pencil** on the separate Answer Sheet.

Read the instructions on the Answer Sheet very carefully.

Each correct answer will score one mark. A mark will not be deducted for a wrong answer.

Any rough working should be done in this booklet.

A copy of the Periodic Table is printed on page 16.

Electronic calculators may be used.

This document consists of **15** printed pages and **1** blank page.

- 1 What is **not** produced by artificial selection?
- A bacteria with antibiotic resistance
 - B cows with high milk yield
 - C sheep with thick wool
 - D wheat with resistance to disease
- 2 What is the effect of vasodilation of arterioles supplying blood to the skin?
- A increased insulation
 - B loss of heat
 - C reduced sweating
 - D shivering
- 3 An enzyme from the alimentary canal has an optimum activity at an acidic pH.
Which statement is correct?
- A The enzyme is an amylase and is found in the mouth.
 - B The enzyme is a protease and is found in the mouth.
 - C The enzyme is an amylase and is found in the stomach.
 - D The enzyme is a protease and is found in the stomach.
- 4 In a plant, what leads to offspring that are identical to the parent?
- A asexual reproduction
 - B insect pollination
 - C seed germination
 - D sexual reproduction

- 5 The diagram shows a river and four farms. The numbers in the river show relative oxygen concentrations.

From which farm is sewage leaking into the river?

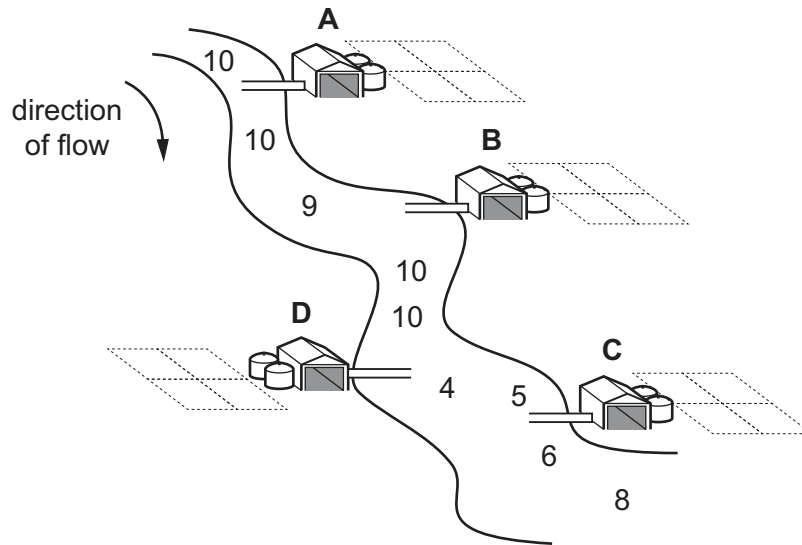

- 6 In a plant, the allele for red flowers is dominant to the allele for yellow flowers. A heterozygous red-flowered plant is crossed with a homozygous yellow-flowered plant.

Which statement about the offspring is correct?

- A** 25% will have red flowers, 75% will have yellow flowers.
- B** 50% will have red flowers, 50% will have yellow flowers.
- C** 75% will have red flowers, 25% will have yellow flowers.
- D** 100% will have red flowers, 0% will have yellow flowers.
- 7 Which structure carries nerve impulses away from the central nervous system?
- A** motor neurone
- B** relay neurone
- C** sensory neurone
- D** spinal cord
- 8 In which part of a flower are the pollen grains produced?
- A** anther
- B** leaf
- C** petal
- D** sepal

9 A blood cell is travelling through the hepatic vein.

Which blood vessel will it travel through next?

- A hepatic artery
- B pulmonary artery
- C pulmonary vein
- D vena cava

10 Which processes occur in **both** animals **and** plants?

	excretion	movement	respiration
A	✓	✓	✓
B	✓	✓	x
C	✓	x	✓
D	x	✓	✓

11 What would indicate that a living tissue was respiring?

- A It produces glucose.
- B It takes in carbon dioxide.
- C It takes in oxygen.
- D It uses up water.

12 A biuret test on a sample of food is positive.

Which nutrient does this result show to be present?

- A fat
- B glucose
- C protein
- D vitamin C

13 Which structural feature is found in a plant cell but **not** in an animal cell?

- A cell membrane
- B cell wall
- C cytoplasm
- D nucleus

14 Which row describes the relative charges on a proton and on an electron?

	proton	electron
A	-1	-1
B	-1	0
C	+1	-1
D	+1	0

15 How many atoms of metals and of non-metals are shown in the formula Na_2SO_4 ?

	atoms of metals	atoms of non-metals
A	1	1
B	1	2
C	2	4
D	2	5

16 The apparatus used for the electrolysis of copper chloride is shown.

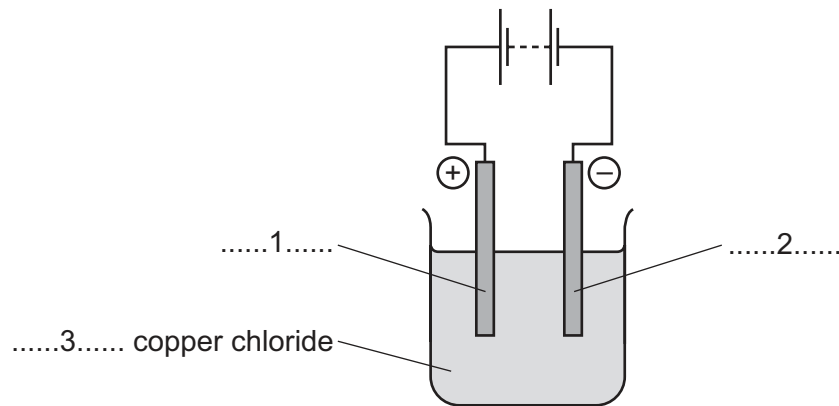

Which words complete labels 1, 2 and 3?

	1	2	3
A	anode	cathode	aqueous
B	anode	cathode	solid
C	cathode	anode	aqueous
D	cathode	anode	solid

17 When sodium is added to water it reacts violently and melts.

Which row describes the type of reaction and how the temperature of the water changes during the reaction?

	type of reaction	temperature of the water
A	endothermic	decreases
B	endothermic	increases
C	exothermic	decreases
D	exothermic	increases

18 Marble (calcium carbonate) reacts with dilute hydrochloric acid.

1 g of powdered marble reacts faster with the same volume and concentration of acid than a 1 g lump of marble.

What is the reason for this observation?

- A** The powder has a larger mass.
- B** The powder has a larger surface area.
- C** The powder has a smaller mass.
- D** The powder has a smaller surface area.

19 In which word equation is the underlined substance being oxidised?

- A** carbon dioxide + carbon → carbon monoxide
- B** carbon monoxide + iron oxide → carbon dioxide + iron
- C** copper oxide + magnesium → magnesium oxide + copper
- D** magnesium oxide + hydrochloric acid → magnesium chloride + water

20 The pH of water changes when ammonia is bubbled into it.

What happens to the pH and why?

	pH	ammonia is
A	decreases	acidic
B	decreases	alkaline
C	increases	acidic
D	increases	alkaline

- 21 Aqueous iron(II) chloride is added to aqueous sodium hydroxide and to aqueous silver nitrate in separate tests.

Which row describes the observations?

	aqueous sodium hydroxide	aqueous silver nitrate
A	green precipitate	white precipitate
B	green precipitate	yellow precipitate
C	red-brown precipitate	white precipitate
D	red-brown precipitate	yellow precipitate

- 22 Four statements about Group VII elements are listed.

- 1 Iodine reacts with both chloride ions and bromide ions.
- 2 Chlorine reacts with both bromide ions and iodide ions.
- 3 Chlorine reacts with bromide ions but not with iodide ions.
- 4 Bromine reacts with iodide ions but not with chloride ions.

Which two statements are correct?

- A** 1 and 2 **B** 1 and 3 **C** 2 and 4 **D** 3 and 4

- 23 Which statement explains why argon is used to fill lamps?

- A** It is a gas.
B It is colourless.
C It is reactive.
D It is unreactive.

- 24 Nickel is a metal.

Three statements about nickel are listed.

- 1 It is a good conductor of electricity.
- 2 It has a low melting point.
- 3 It is shiny.

Which statements about the properties of nickel are correct?

- A** 1 and 2 **B** 1 and 3 **C** 1 only **D** 2 and 3

25 Which row shows a chemical test for the presence of water?

	substance	colour change
A	anhydrous cobalt(II) chloride	pink to blue
B	anhydrous cobalt(II) chloride	white to blue
C	anhydrous copper(II) sulfate	pink to blue
D	anhydrous copper(II) sulfate	white to blue

26 Why do farmers add lime to soil?

- A** It acts as a fertiliser.
- B** It adds nitrogen to the soil.
- C** It decreases the pH of the soil.
- D** It increases the pH of the soil.

27 Which statement describes cracking?

- A** converting alkanes to alkenes
- B** forming poly(ethene) from ethene
- C** reacting alkenes with bromine
- D** reacting ethene with oxygen

28 Which diagram shows the distance-time graph for an object moving with constant speed?

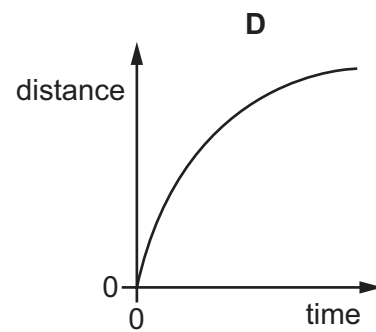
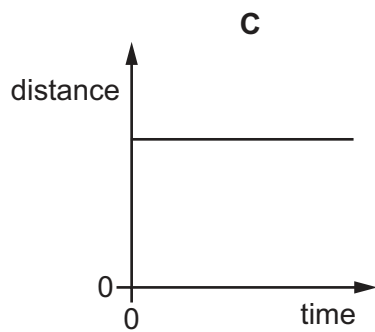
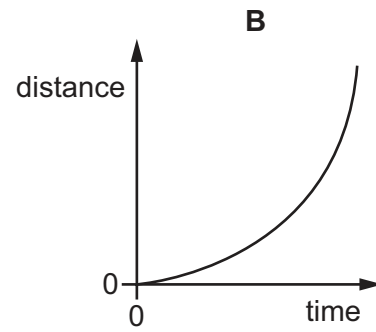
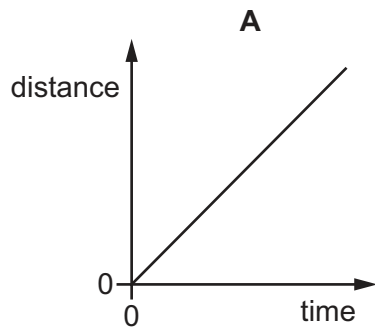

29 Two blocks of metal, X and Y, hang from spring balances as shown.

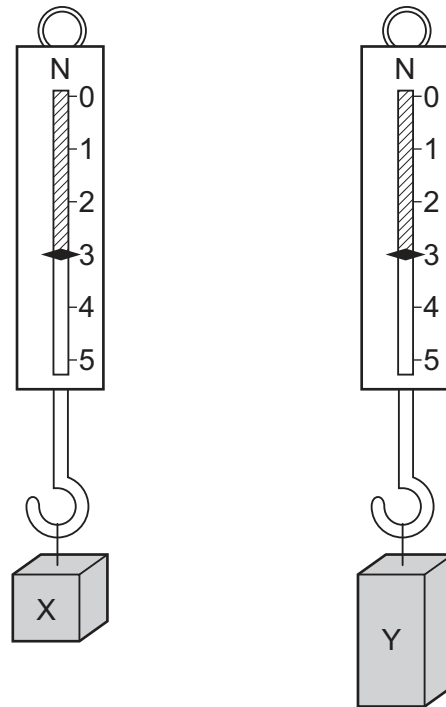

What does the diagram show about X and Y?

- A They have the same mass and the same volume but different weights.
 - B They have the same mass and the same weight but different volumes.
 - C They have the same mass, the same volume and the same weight.
 - D They have the same weight and the same volume but different masses.
- 30 Which situation is an example of a force acting over a large area to produce a small pressure?
- A a nail penetrating a piece of wood
 - B a needle being inserted into a patient's arm
 - C a sharp knife cutting vegetables
 - D a soldier marching in flat-soled boots

31 A solid sample of a material in a container is supplied with thermal energy at a constant rate.

The temperature of the material is recorded every two minutes for 20 minutes.

The results are shown in the table.

time/min	0	2	4	6	8	10	12	14	16	18	20
temperature / °C	53.7	55.9	58.0	60.1	62.1	62.1	62.1	64.0	66.9	69.0	70.9

How should the sample be described at the end of the 20 minutes?

- A all solid
- B all liquid
- C all gas
- D in the process of melting

32 Bread can be cooked by placing it below a heating element.

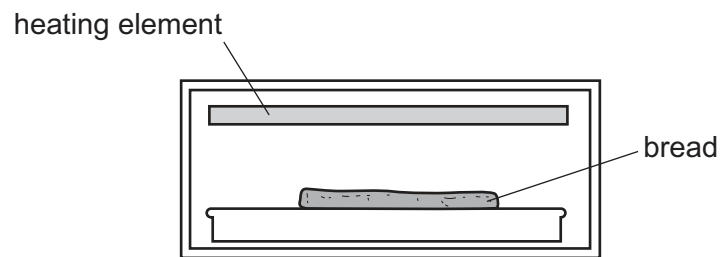

Which process transfers thermal energy from the heating element to the bread?

- A conduction
- B convection
- C evaporation
- D radiation

33 The diagrams represent four waves. The diagrams are drawn to the same scale.

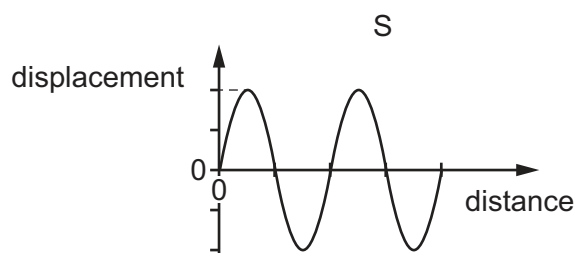
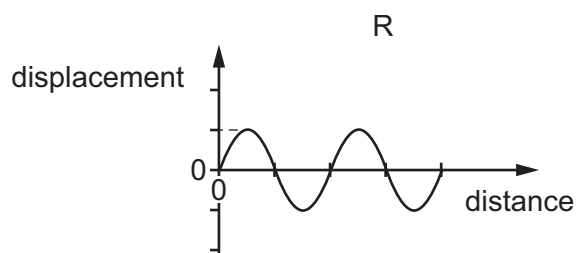
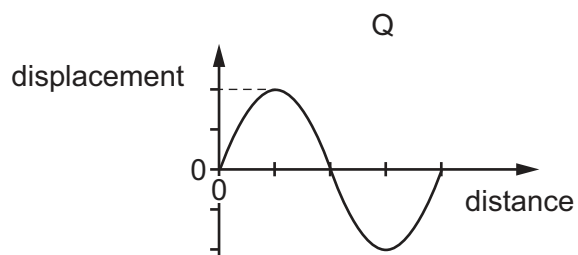
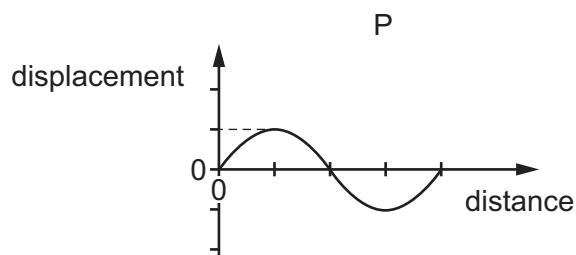

Which statement is correct?

- A The amplitude of wave P is the same as the amplitude of wave R.
- B The amplitude of wave S is twice the amplitude of wave Q.
- C The wavelength of wave Q is twice the wavelength of wave P.
- D The wavelength of wave S is the same as the wavelength of wave Q.

34 The diagram shows a ray of light passing through a glass block.

Which labelled angle is an angle of refraction?

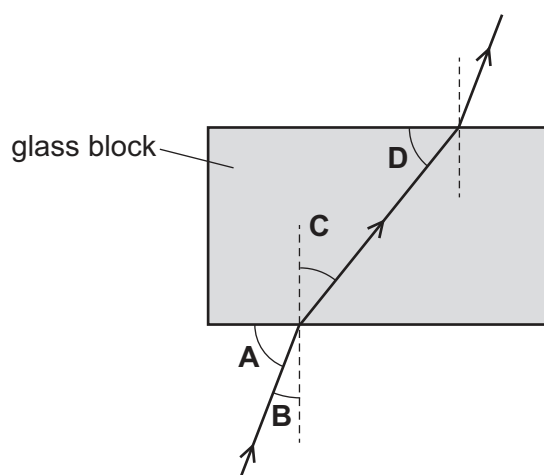

- 35 Astronaut 1 uses a hammer to mend a satellite in space. Astronaut 2 is nearby. There is no air in space.

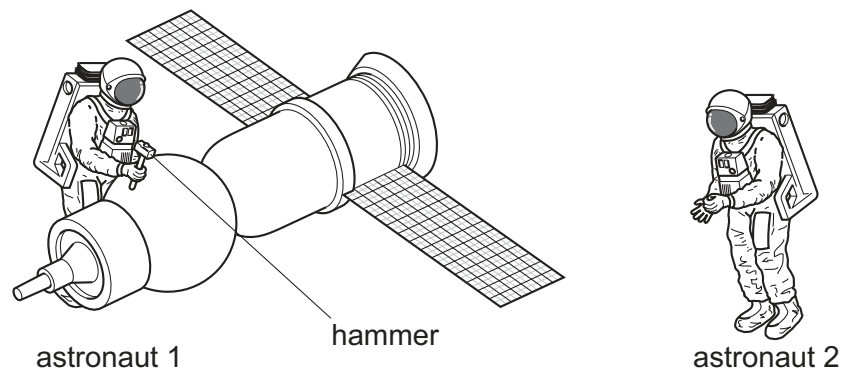

What does astronaut 2 hear compared with the sound heard if they were working on Earth?

- A a louder sound
 - B a quieter sound
 - C a sound of the same loudness
 - D no sound at all
- 36 A student makes an electromagnet with a steel core.

The electromagnet does not work well.

Which problem with the electromagnet is caused by using a steel core?

- A It does not become magnetised at all.
 - B It has the same type of magnetic pole at each end.
 - C It remains magnetised when it is switched off.
 - D It repels unmagnetised magnetic materials.
- 37 Which quantities can be measured using a voltmeter?
- A current and e.m.f. only
 - B current and p.d. only
 - C e.m.f. and p.d. only
 - D e.m.f., current and p.d.

- 38 The diagram shows a 6.0 V battery connected to a 3.0 Ω resistor.

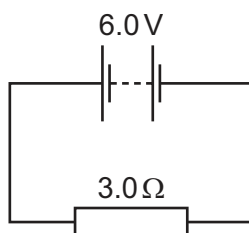

What is the current in the resistor?

- A 0.50 A B 2.0 A C 9.0 A D 18 A
- 39 A battery is connected to a 3.0 Ω resistor, a 6.0 Ω resistor and two ammeters P and Q.

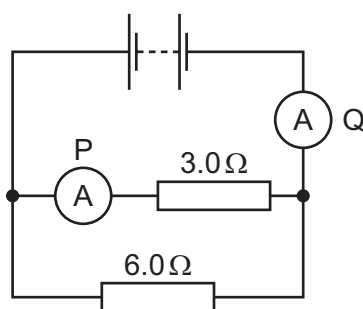

What is the combined resistance of the two resistors and which ammeter has the greater reading?

	combined resistance / Ω	ammeter with greater reading
A	less than 3.0	P
B	less than 3.0	Q
C	9.0	P
D	9.0	Q

- 40 Which row compares the number of protons and the number of neutrons in atoms of different isotopes of an element?

	number of protons	number of neutrons
A	different	different
B	different	the same
C	the same	different
D	the same	the same

BLANK PAGE

Permission to reproduce items where third-party owned material protected by copyright is included has been sought and cleared where possible. Every reasonable effort has been made by the publisher (UCLES) to trace copyright holders, but if any items requiring clearance have unwittingly been included, the publisher will be pleased to make amends at the earliest possible opportunity.

To avoid the issue of disclosure of answer-related information to candidates, all copyright acknowledgements are reproduced online in the Cambridge International Examinations Copyright Acknowledgements Booklet. This is produced for each series of examinations and is freely available to download at www.cie.org.uk after the live examination series.

Cambridge International Examinations is part of the Cambridge Assessment Group. Cambridge Assessment is the brand name of University of Cambridge Local Examinations Syndicate (UCLES), which is itself a department of the University of Cambridge.

The Periodic Table of Elements

		Group															
I	II	III	IV	V	VI	VII	VIII										
3 Li lithium 7	4 Be beryllium 9	<div style="border: 1px solid black; padding: 5px; width: fit-content; margin: auto;"> Key atomic number atomic symbol name relative atomic mass </div>										2 He helium 4					
11 Na sodium 23	12 Mg magnesium 24											5 B boron 11	6 C carbon 12	7 N nitrogen 14	8 O oxygen 16	9 F fluorine 19	10 Ne neon 20
19 K potassium 39	20 Ca calcium 40	21 Sc scandium 45	22 Ti titanium 48	23 V vanadium 51	24 Cr chromium 52	25 Mn manganese 55	26 Fe iron 56	27 Co cobalt 59	28 Ni nickel 59	29 Cu copper 64	30 Zn zinc 65	31 Ga gallium 70	32 Ge germanium 73	33 As arsenic 75	34 Se selenium 79	35 Br bromine 80	36 Kr krypton 84
37 Rb rubidium 85	38 Sr strontium 88	39 Y yttrium 89	40 Zr zirconium 91	41 Nb niobium 93	42 Mo molybdenum 96	43 Tc technetium —	44 Ru ruthenium 101	45 Rh rhodium 103	46 Pd palladium 106	47 Ag silver 108	48 Cd cadmium 112	49 In indium 115	50 Sn tin 119	51 Sb antimony 122	52 Te tellurium 128	53 I iodine 127	54 Xe xenon 131
55 Cs caesium 133	56 Ba barium 137	57–71 lanthanoids	72 Hf hafnium 178	73 Ta tantalum 181	74 W tungsten 184	75 Re rhenium 186	76 Os osmium 190	77 Ir iridium 192	78 Pt platinum 195	79 Au gold 197	80 Hg mercury 201	81 Tl thallium 204	82 Pb lead 207	83 Bi bismuth 209	84 Po polonium —	85 At astatine —	86 Rn radon —
87 Fr francium —	88 Ra radium —	89–103 actinoids	104 Rf rutherfordium —	105 Db dubnium —	106 Sg seaborgium —	107 Bh bohrium —	108 Hs hassium —	109 Mt meitnerium —	110 Ds darmstadtium —	111 Rg roentgenium —	112 Cn copernicium —	114 Fl flerovium —	116 Lv livermorium —	—	—	—	—

lanthanoids	57 La lanthanum 139	58 Ce cerium 140	59 Pr praseodymium 141	60 Nd neodymium 144	61 Pm promethium —	62 Sm samarium 150	63 Eu europium 152	64 Gd gadolinium 157	65 Tb terbium 159	66 Dy dysprosium 163	67 Ho holmium 165	68 Er erbium 167	69 Tm thulium 169	70 Yb ytterbium 173	71 Lu lutetium 175
actinoids	89 Ac actinium —	90 Th thorium 232	91 Pa protactinium 231	92 U uranium 238	93 Np neptunium —	94 Pu plutonium —	95 Am americium —	96 Cm curium —	97 Bk berkelium —	98 Cf californium —	99 Es einsteinium —	100 Fm fermium —	101 Md mendelevium —	102 No nobelium —	103 Lr lawrencium —

The volume of one mole of any gas is 24 dm³ at room temperature and pressure (r.t.p.).